

# BENCH CENTER WITH ROLLER TAILSTOCKS

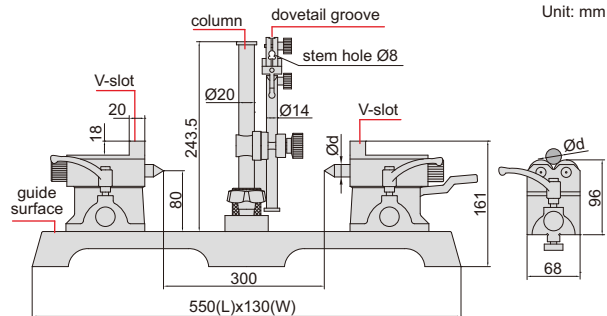

4720-300

- Hardened cast-iron guide surface
- Supplied with V-slot/center tailstocks and roller tailstocks
- V-slot for cylinder  $\text{Ø}4\sim 22\text{mm}$
- Roller for cylinder  $\text{Ø}5\sim 100\text{mm}$



Unit: mm

roller tailstocks (included)

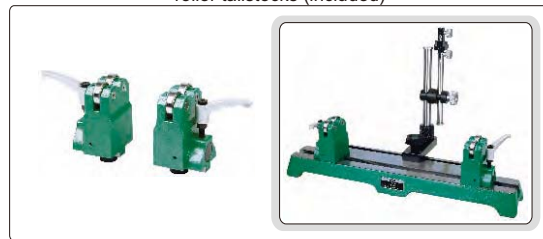

Code	Parallelism *	Runout accuracy	Center height	Distance between two centers	Diameter of center (Ød)	Taper of center	Load
4720-300	0.01mm	2 $\mu\text{m}$	80mm	300mm	16mm	MT1	25kg (40kg for roller tailstocks)

\*Parallelism of two centers to the guide surface